

OWNER'S MANUAL

Model 449-M *55 Gallon (220 Litre) Automatic Preservative* *Applicator*



P.O. Box 63 • 2821 Harvey Street • Hudson, WI 54016
800-635-7468 • www.harvesttec.com

#010-0449M

REVISED 1-08

HARVEST TEC 449 TABLE OF CONTENTS

	<u>PAGE</u>
INSTALLATION KIT REFERENCE CHART	3
TOOLS NEEDED	3
INSTALLATION OF APPLICATOR	4-15
1. INSTALLATION OF TANK	4
2. INSTALLATION OF MOUNTING BRACKETS	4-5
JOHN DEERE EUROPEAN BALERS	4
VICON 1601/1901	5
3. INSTALLATION OF PUMP PLATE	6
4. INSTALLATION OF DRAIN/FILL KIT	7
5. PLACEMENT OF SPRAY NOZZLE ASSEMBLY	8-9
VICON 1601/1901	8
JOHN DEERE EUROPEAN BALERS	9
6. INSTALLATION OF PLUMBING	10
HIGH AND LOW OUTPUT TIPS	10
7. INSTALLATION OF MOISTURE SENSING PADS	11-13
VICON 1601/1901	11-12
JOHN DEERE EUROPEAN BALERS	13
8. POWER CABLE AND MAIN WIRING HARNESS INSTALLATION	14-15
SYSTEM WIRING DIAGRAM	14
INSTALLATION OF CONTROL	15
9. DESCRIPTION OF BUTTONS	16
10. FIRST TIME AND ANNUAL START UP INSTRUCTIONS	17
CHECKING AND PRIMING THE PUMPS	17
11. SETTING UP SYSTEM FOR INITIAL USE	18-19
APPLICATION RATE	18
BALING RATE	19
OPERATING INSTRUCTIONS	20-23
AUTOMATIC MODE	20
MANUAL MODE	21
JOB RECORDS	22
DIAGNOSTICS	23
COMMON QUESTIONS ABOUT THE 463	24
MAINTENANCE	25
WINTER STORAGE	25
TROUBLE SHOOTING CHECKS	26-27
BACKUP FUSE	27
WIRING DIAGRAMS	28-29
PARTS BREAKDOWN	30-35
MODEL 449 BASE KIT	30
DRAIN FILL KIT	30
PUMP PLATE	31
MOISTURE PAD AND HOSES	32
CONTROL BOX AND WIRING HARNESS	33
4503B FOR JOHN DEERE EUROPEAN BALERS	34
4512B FOR VICON 1601/1901	35
NOTES	36
WARRANTY STATEMENT	BACK PAGE

INTRODUCTION

Congratulations on purchasing a Harvest Tec Model 449 applicator. This applicator is designed to apply Harvest Tec buffered propionic acid. The model 449 base kit includes the following parts: Tank, Frame, Pumps, Hose, Baler Mounted Processor, Touch Screen Display, Moisture Sensors, and Miscellaneous Hardware. The applicator can be installed on most round balers with the proper installation kit. Before installing the unit on the baler, make sure you have the proper installation kit. (See the chart below.) If you are unsure about your installation kit contact your dealership for specifications. For your convenience we have included a parts breakdown for the model 449 applicator. If something goes wrong, bring this manual into the dealership so they can order the correct parts for you. Ordering the correct part number is very important. It will save you time, money, and your crop

INSTALLATION KIT REFERENCE CHART

<u>BALER MAKE</u>	<u>BALER MODEL</u>	<u>INSTALLATION KIT</u>
JOHN DEERE	582 ROUND BALERS	4503B
JOHN DEERE	5, 6, AND 7 SERIES ROUND BALERS	4504B
VERMEER	604M AND 605M ROUND BALERS	4505B
HESSTON	800 AND 900 SERIES ROUND BALERS	4508B

TOOLS NEEDED

- Standard wrench set
- Standard socket set
- Standard screw driver or 5/16" nut driver
- Side cutter
- Hose cutter
- Crescent wrench
- Hammer
- Metal drilling and cutting tools
- Center Punch

1. INSTALLATION OF TANK

Place tank (005-9203) onto saddle (001-4703). Make sure side tank fitting is placed to the baler's left side when looking at it from the front. Attach straps (001-4402) to saddle using 5/16" x 4" bolts. Make sure to double nut all four bolts.

2. INSTALLATION OF MOUNTING BRACKETS

John Deere European balers

The mounting brackets are L-shaped. There is a right and left bracket enclosed in the applicator. This can be determined by setting the right and left bracket next to each other with the longer legs laying flat toward you and the shorter legs pointing up. The short leg of the bracket will either touch each other or angle away from each other. Place the brackets so they angle away from each other and form a **V** (see below). The bracket on the left is the left bracket and the bracket to the right is the right bracket.

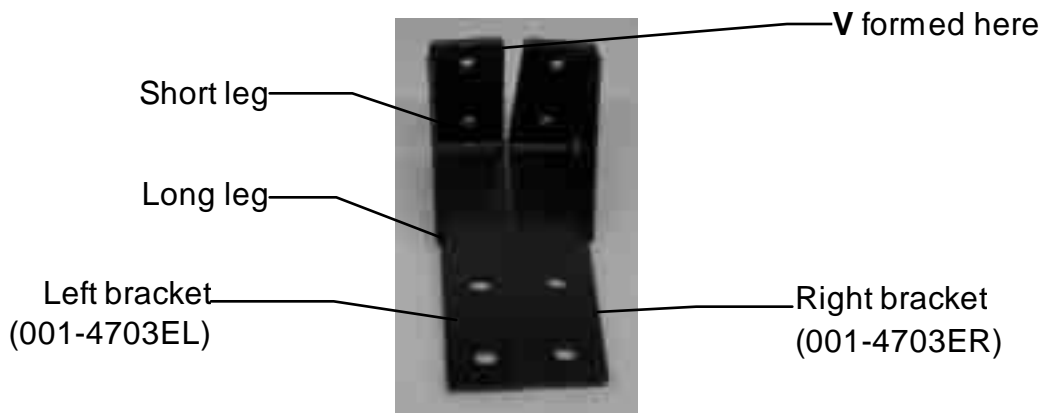

Before installing the brackets, the baler tongue must be supported by some means other than the jack (ex. hooked to a tractor). Looking at the baler from the front, the right bracket bolts to the left side of the hitch using two M16 x 55mm bolts, washers, lock washers, and nuts (labeled **L1** below). Short leg of brackets will point toward the front of the hitch. Next remove the two bolts holding the jack assembly to a baler (labeled **L2** below). Insert the right L-bracket between the jack assembly and baler. Bolt together with two M16 x 70mm bolts. Attach the tank legs (001-4703B) to the tank saddle with 3/8" x 1" bolts, locks, and flat washers. Attach the saddle legs to the mounting bracket with 1/2" x 1 1/2" bolts, locks, nuts and flat washers.

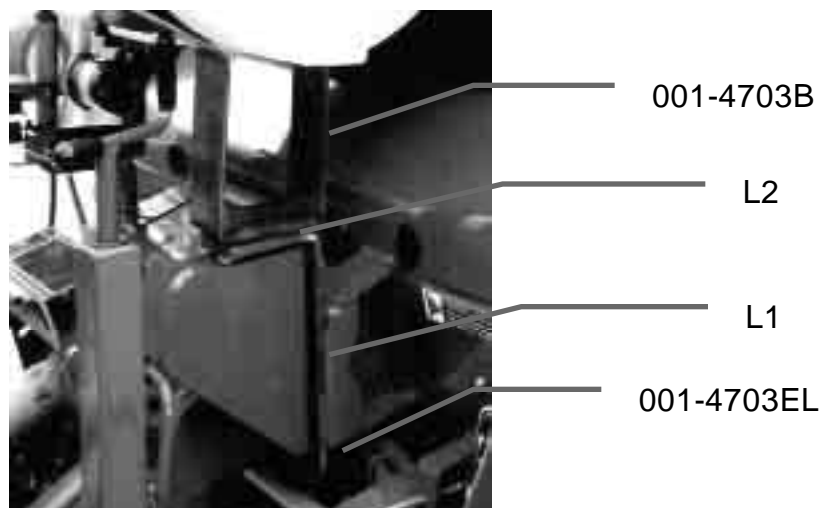

Vicon 1601/1901

On the front of the baler directly above the pickup head locate the parallelogram shaped metal beam. Mark the holes on the beam by aligning the mounting brackets (001-4704F) to the top edge of the beam and drill, using a 9/16" (14 mm), the four holes that correspond with the mounting brackets (001-4704F) and attach using the 1/2" x 5" bolts securing with lock and flat washers and nuts. Attach the saddle legs to the mounting bracket with 1/2" x 1 1/2" bolts, locks, nuts and flat washers.

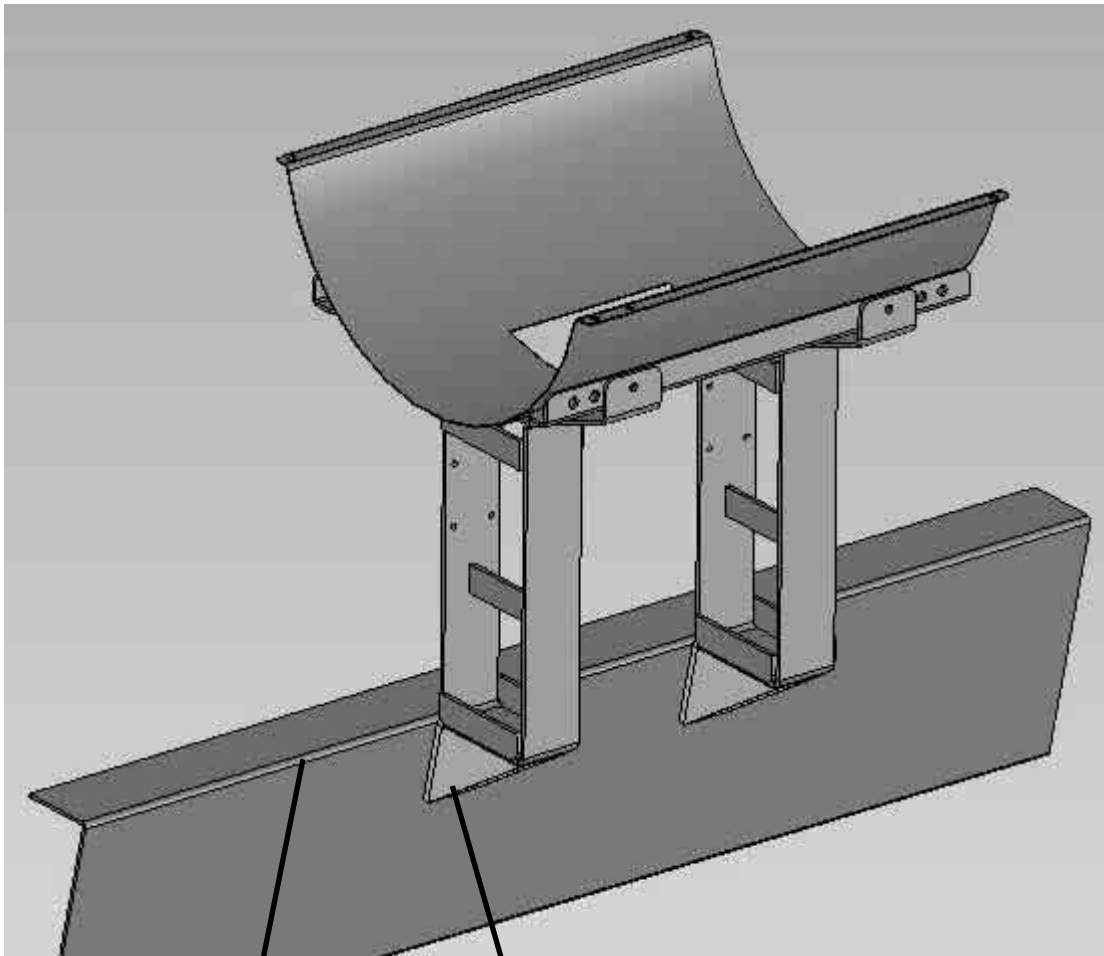

Align brackets
to this edge

001-4704F

3. INSTALLATION OF THE PUMP PLATE

All round balers

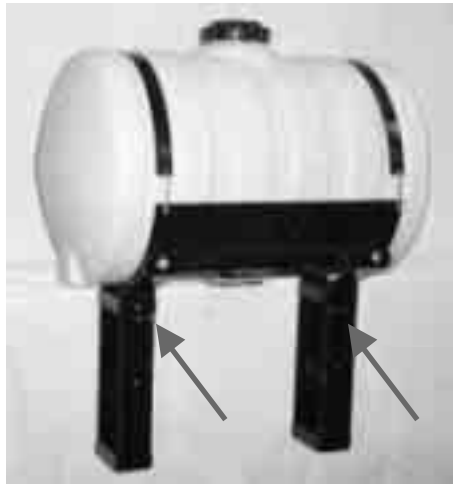

Figure 1



Figure 2



Figure 3

1. Locate the two mounting holes as shown in Figure 1.
2. Connect the pump plate mounting bracket (001-4646C), shown in Figure 2, using two 3/8 x 1 1/4 bolts, nuts, locks, and flat washers to the saddle.
3. Attach the pump plate holder (001-4646D) to pump plate mounting bracket (001-4646C) using four 3/8 x 3/4 flange head bolts. Figure 3.

The Baler Mounted Processor and pump heads must be pointing down. Failure to mount the pump plate assembly in this specified direction will void all warranty of the Baler Mounted Processor and pumps.

4. INSTALLATION OF DRAIN/FILL KIT

Thread 3/4" elbow fitting (#003-EL3434) into end of tank. Run 3/4" hose from the elbow down the frame to the bottom of the baler. Drill 1/4" holes to accept the valve holder bracket and use 5/16" x1 1/4" self-tapping screws. Connect valve assembly to other end of hose. Place hose clamps on both ends.

*Secure hose to frame using cable locks.



5. PLACEMENT OF SPRAY NOZZLE ASSEMBLY

Vicon 1601/1901

Mount the shield to the baler tongue as shown in Figure 1. Mark the two holes on the baler tongue and drill with a 7/16" (11 mm) drill bit. Attach the shield to the baler with 3/8" x 1" bolts, locks, nuts, and flat washers.

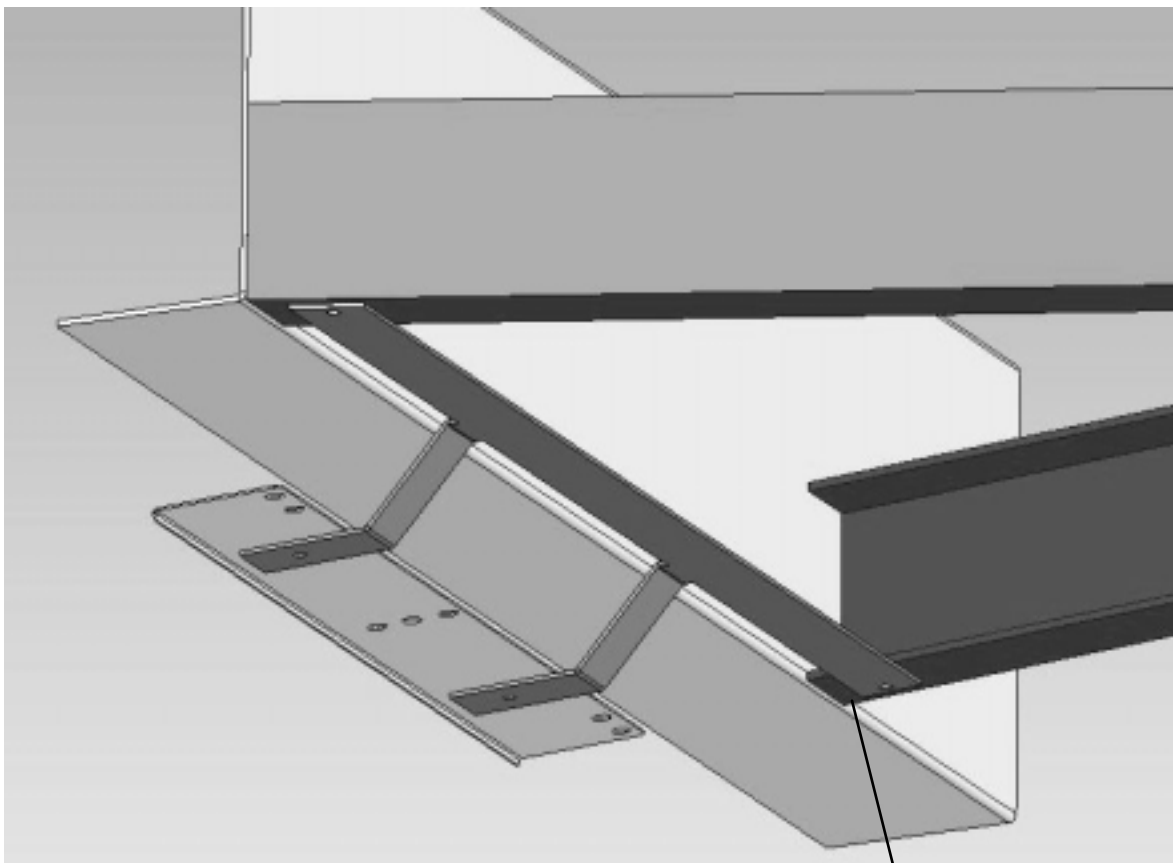

Figure 1

For John Deere European balers

The top cross bar above the full-shielded wind guard provides a mounting point for the short nozzle pipes. (Figure 1) Holes will need to be drilled in the wind guard for the pipes to spray through. Use a 1 1/2" hole saw to make these holes. Space the nozzles by the chart below:



Figure 1

PICK-UP HEAD WIDTH	LEFT SIDE (Use plugged fitting)	CENTER (Use 2-way fitting)	RIGHT SIDE (Use 2-way fitting)
48" (122 cm)	12" from left (30 cm)	Center	12" from right (30 cm)
60" (152 cm)	14" from left (36 cm)	Center	14" from right (36cm)
72" (183 cm)	15" from left (38 cm)	Center	15" from right (38 cm)

6. INSTALLATION OF PLUMBING

A. Intake

Use the 003-EL3412 on the bottom of the tank to route 1/2" line (002-9001) to the 003-A1212 fitting on the ball valve already attached to the pump plate. Attach hose clamps (003-9003) on both of the fittings.

B. Discharge

The three – 1/4" hose assembly will be used to attach the pumps to the spray shield. The pump order is, from closest to the filter bowl, 1,2 and 3. Pump 1 will attach to the three tees plumbed together on the shield or to the three main nozzle tubes. This is done by connecting the hose to one of the nozzles on the end that has two hose barb fittings. Continue to connect these nozzles together with the clear hose to the end nozzle (which is capped off). Pump 2 will use the green hose and pump 3 will use the blue hose to attach to the auxiliary nozzles.

C. High and Low Output Tips

Your baler comes with two sets of tips: a low set and a high set.

-The low set will cover outputs of 32 to 440 lbs/hr or approximately 8-27 tons/hour.

Install the following tips for low output:

Clear hose to silver tips on all three tubes.

Green hose to green tip.

Blue hose to red tip.

-The high set will cover outputs of 84 to 632 lbs/hr or approximately 21-40 tons/hour.

Install the following tips for high output:

Clear hose to white outside tips and orange middle tip.

Green hose to blue tip.

Blue hose to gray tip.

****Refer to Tip Output under APPLICATION RATE of the control unit to calibrate system.**

7. INSTALLATION OF MOISTURE SENSING PADS

For all Vicon round balers

1. If your baler is not equipped with bale shaping pads you will need to drill a hole in the chamber directly behind and above the starting roll. (Figure 1)
2. You will need to remove the jockey gear to install the pad on the right side of baler (when facing front of baler). (Figure 2)
3. The inside lip of the jockey gear will need to be removed for the moisture sensor bolt to clear. The hole size is 3/4" (19 mm) diameter. Before drilling the hole, make sure hole is accessible from opposite side of chamber to tighten down mounting hardware and to install moisture harness. (Figure 3)

Figure 1



Figure 2

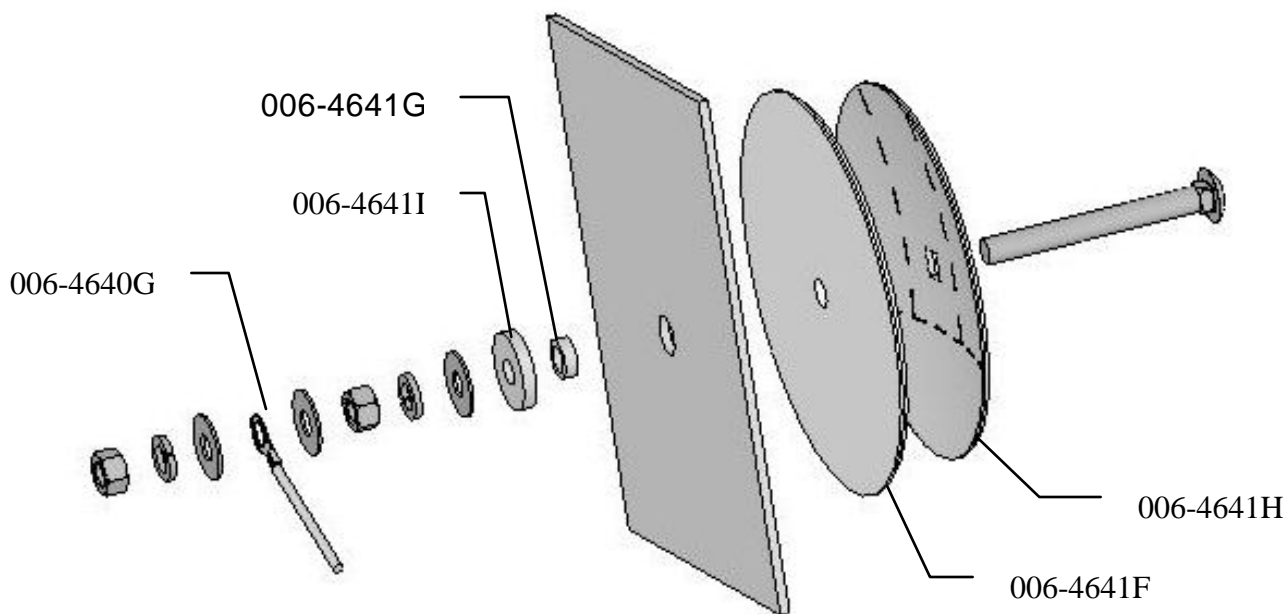

Figure 3



CONTINUED ON NEXT PAGE

For all Vicon round balers



5. Locate the 006-4641G. The piece will need to be cut down to size. Use the already machined line in the bushing to cut off the small piece shown above.
6. Depending on the baler the bolt may need to be trimmed for proper fit.
7. Tighten all of the hardware to 50 ft/lbs.
8. Make sure that the plastic pad is protecting all metal surfaces of the disc from touching baler. (Figure 4)
9. Run the moisture wire harness (006-4640G) from pump plate area to each disc securing with cable ties.
10. Apply silicone over nuts and washers.

For John Deere European baler

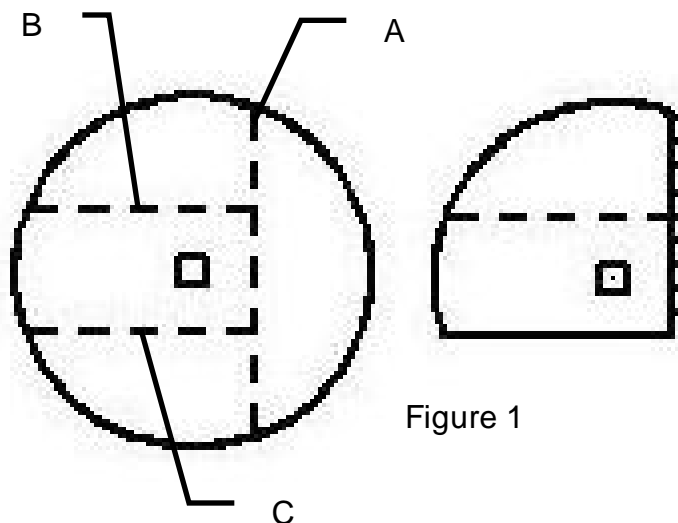

Figure 1

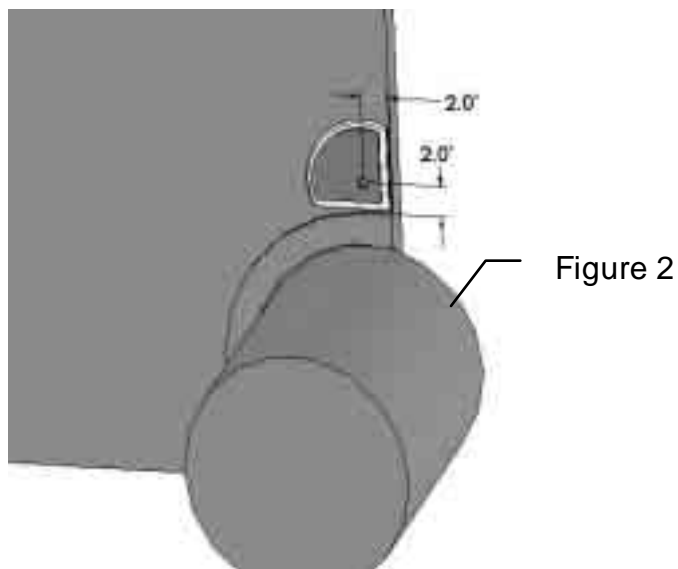
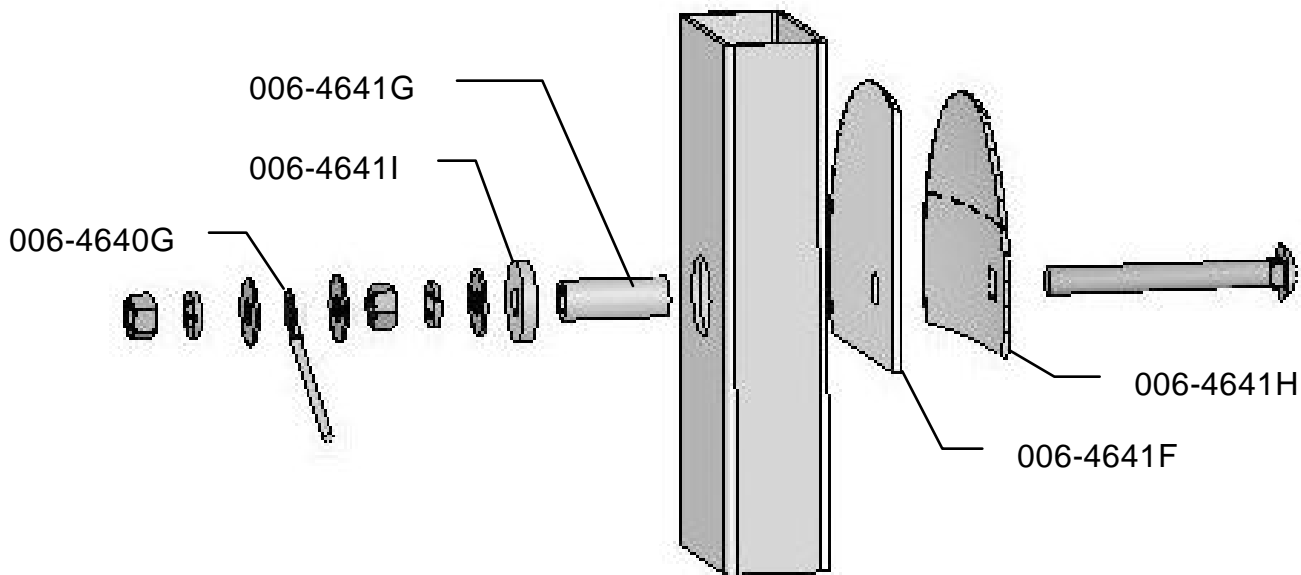

Figure 2

1. The moisture discs (006-4641H) will both need to be cut on line A. (Figure 1) One disc will need to be cut on line B and one disc on line C.
2. The plastic pad (006-4641F) will also need to be cut 1/4" longer than the back of the disc.
3. The mounting hole will be 3/4" in diameter. The disc will need to be placed on the baler to line up the location of 2" up from bottom and 2" from the back of the chamber to the center of the bolt. (Figure 2)



4. Make sure that plastic pad is protecting all metal surfaces of disc from touching baler.
5. Run the moisture wire harness (006-4640G) from pump plate area to each disc securing with cable ties.
6. On some balers the bolt may need to be trimmed for proper fit.
7. Tighten all hardware to 50 ft/lbs.
8. Apply silicone over nuts and washers.

8. POWER CABLE AND MAIN WIRING HARNESS INSTALLATION

1. Locate the power harness.
2. Connect the power harness (006-4640A) to the battery (12 volt) using the red wire with fuse to the positive side and the black wire to the negative.



a. The power harness must be connected to the battery! The unit will draw more amps than convenience outlets can handle. Any modifications of the power harness will void systems warranty. **CONTACT HARVEST TEC IF MODIFICATION IS REQUIRED!**

b. This unit will not function on positive ground tractors.

c. If the unit loses power while operating it will not keep track of accumulated pounds of product used.

3. The Power Harness (006-4640A) will run from the tractor battery to the hitch. The Power Harness (006-4660R) will connect to the Tractor Power Harness (006-4640A) at the hitch. Run the Communication Harness (006-4660N) from the cab to the hitch. This wire will connect to the Communication Harness (006-4660S). These wires will run together to the Baler Mounted Processor (006-4671RB).
4. Connect Flow Meter (006-4725A) to the Baler Mounted Processor.
5. Connect Pump Harness (006-4660Z) the Baler Mounted Processor.
6. If you have the optional Hay Indicator, connect it to the Baler Mounted Processor.
7. Attach moisture cable (006-4640G) to Baler Mounted Processor.
8. Install Baler Mounted Processor in pump plate using 5/16" lock, nut, and flat washers.

NOTE: The plugs on the Baler Mounted Processor must face down. Failure to mount correctly will void systems warranty.

SYSTEM WIRING DIAGRAM

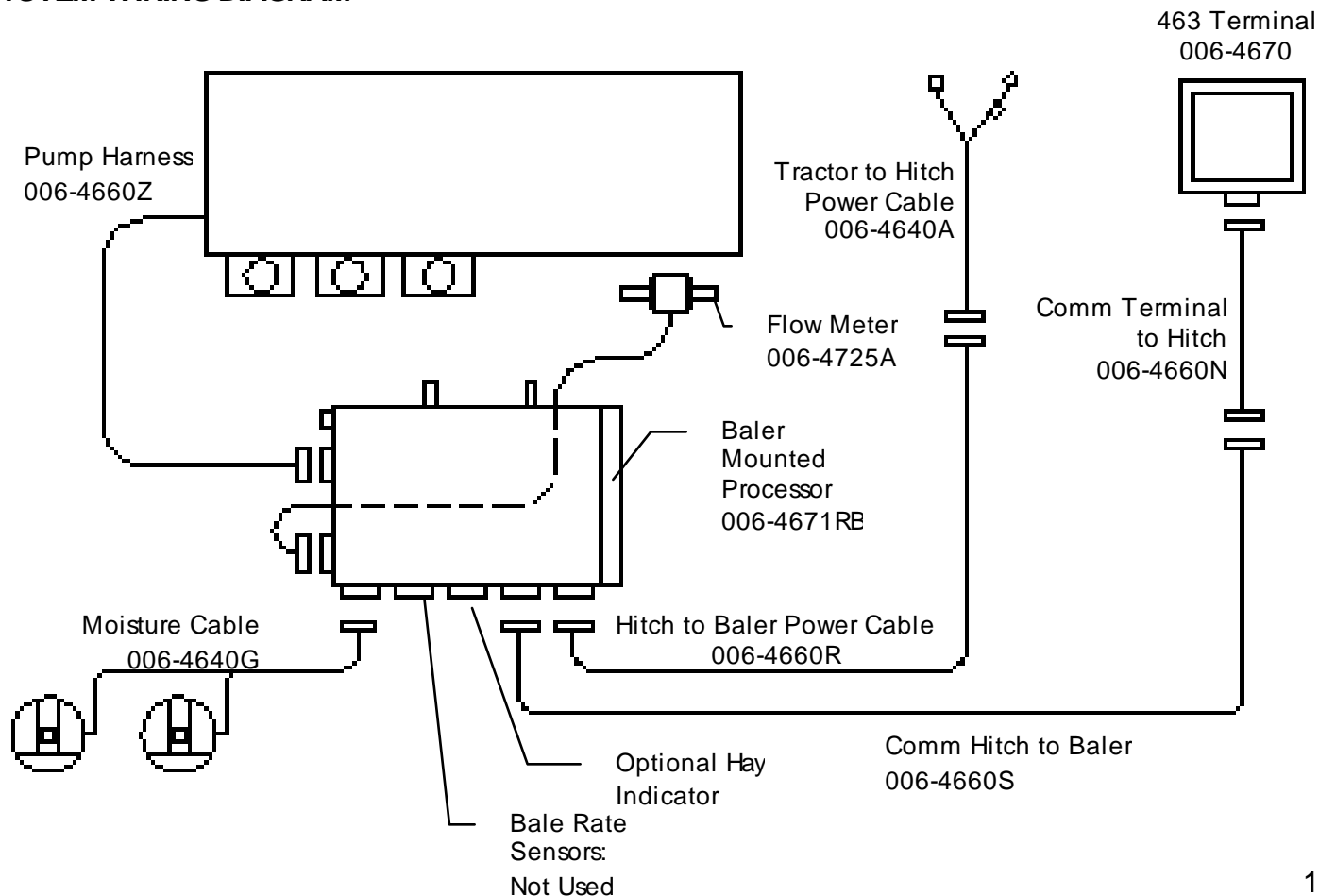

INSTALLATION OF CONTROL

INSTALL THE MOUNTING BRACKET FOR THE CONTROL IN THE CAB.

Use the four mounting screws to mount the round base in a convenient area in your cab or on your fender. If unit is mounted on the fender it will need to be removed at night and stored in a clean and dry area. If the fender is loose additional vibration will occur.

Use the ram mount swivel-positioning nut to tighten the entire assembly. Adjust it so that you can view the entire screen and be able to use the touch screen without interfering with other tractor functions.

Connect communication wire (006-4660N) to the bottom of the terminal.

9. DESCRIPTION OF BUTTONS

This system is calibrated for use with Harvest Tec buffered propionic acid. It is designed to apply rates of 32 to 632 pounds (14 to 270 litres) of acid per hour and read moisture levels of 10 to 32 percent. The 463 monitor will allow you to set your bale weight, single bale formation time, moisture levels and application rates. The Automatic Mode will automatically adjust the application rates as the moisture levels change. Manual Mode will allow you to control the application rates on the go. To turn the display on touch anywhere on the right side of the screen followed by pushing the "Press to Start" key.

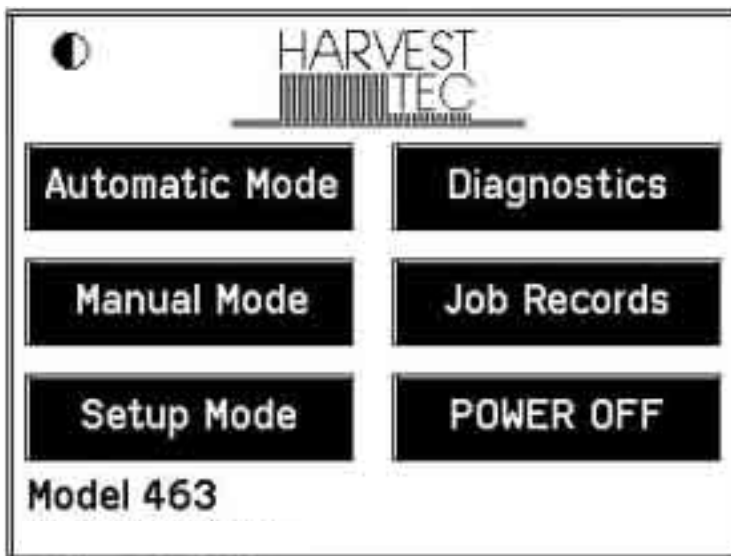

AUTOMATIC MODE This mode allows you to use all of the applicators features such as adjusting preservative application on the go and counting total pounds of product used.

MANUAL MODE Allows operator to manually turn pumps on and off. This mode also has moisture content displayed. Use this mode to prime pumps.

SETUP MODE This mode allows the operator to adjust bale rate and application rate settings and view or change tip selection.

DIAGNOSTICS Allows operator to automatically check performance and output of pumps as well as set the date and time.

JOB RECORDS Keeps track of up to 63 jobs with total product used, average moisture content, tons baled, and date of baling.

POWER OFF This key turns the unit off. Press anywhere on the right side of the screen to turn the unit on.

 **CONTRAST** This button is your contrast control. Press this button to lighten the screen. When the screen reaches its lightest point, pressing again will return to the darkest setting. Fine tuning the contrast can be accomplished by turning the knob on the bottom right side of the enclosure.

10. FIRST TIME AND ANNUAL START UP INSTRUCTIONS

AFTER INSTALLATION THE UNIT MUST BE CHECKED OUT BEFORE FIELD OPERATION!!

CHECKING AND PRIMING THE PUMPS

1. Put 10 gal (40 litres) of water in tank and turn main ball valve on.
2. Inspect for any leaks or drips at this time. If any are found tighten or replace area or fitting.
3. **Turn controller on** (push anyw here on the right side of screen follow ed by the press to start key).
4. Press the MANUAL MODE key.
5. The screen show n below should appear.

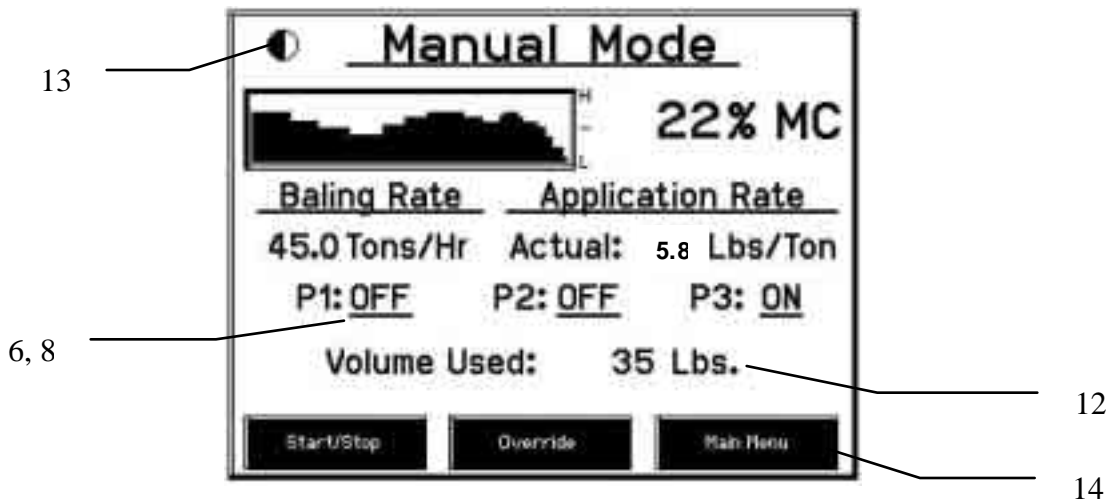

NOTE: THE SYSTEM COMES WITH THE HIGH TIPS ALREADY INSTALLED ON THE SPRAY SHIELD OR NOZZLE TUBES. TEST SYSTEM WITH TIPS YOU WILL USE MOST OFTEN.

6. **With low tips in:** Turn pump 1 on (P1). To do this press the underlined area on the screen which says OFF. The application rate should then read between 0.7 – 1.2 Lbs/Ton (.3 – .5 L/MT). Ideally, at 13.5 volts, the rate would read 1.0 Lbs/Ton (0.4 L/MT).
7. Repeat the process for pumps 2 and 3 (P2 and P3). The application rate should read between 1.7 – 2.4 Lbs/Ton (0.7 – 1.0 L/MT) and 2.5 – 3.5 Lbs/Ton (1.1 – 1.5 L/MT) respectively. Ideally, at 13.5 volts, the rate for pump 2 would be 2.0 Lbs/Ton (0.8 L/MT); pump 3 would be 3.0 Lbs/Ton (1.3 L/MT).
8. **With high tips in:** Turn pump 1 on (P1). To do this press the underlined area on the screen which says OFF. The application rate should then read between 1.3 – 1.9 Lbs/Ton (0.5 – 0.8 L/MT). Ideally, at 13.5 volts, the rate would read 1.6 Lbs/Ton (0.7 L/MT).
9. Repeat the process for pumps 2 and 3 (P2 and P3). The application rate should read between 2.6 – 3.6 Lbs/Ton (1.1 – 1.5 L/MT) and 4.9 – 6.8 Lbs/Ton (2.1 – 2.9 L/MT) respectively. Ideally, at 13.5 volts, the rate for pump 2 would be 3.1 Lbs/Ton (1.3 L/MT); pump 3 would be 5.8 Lbs/Ton (2.4 L/MT).
10. This process will also be used to prime the pumps whenever needed.
11. While running pumps check for a good spray pattern out of the respective tips and verify that no parts of the system are leaking.
12. While doing these tests the Volume Used on the bottom of the screen should be counting up, this verifies that the flow meter is functioning.
13. This button is your contrast control. Press this button to darken the screen. When the screen reaches its darkest point, when the button is next depressed it will return to lightest setting.
14. Press the MAIN MENU key to return to the initial start up screen.

11. SETTING UP SYSTEM FOR INITIAL USE

In this mode you will setup your initial application rate and baling rate.

APPLICATION RATE

After pushing the SETUP MODE key in the Main Menu screen, the top left screen should appear:

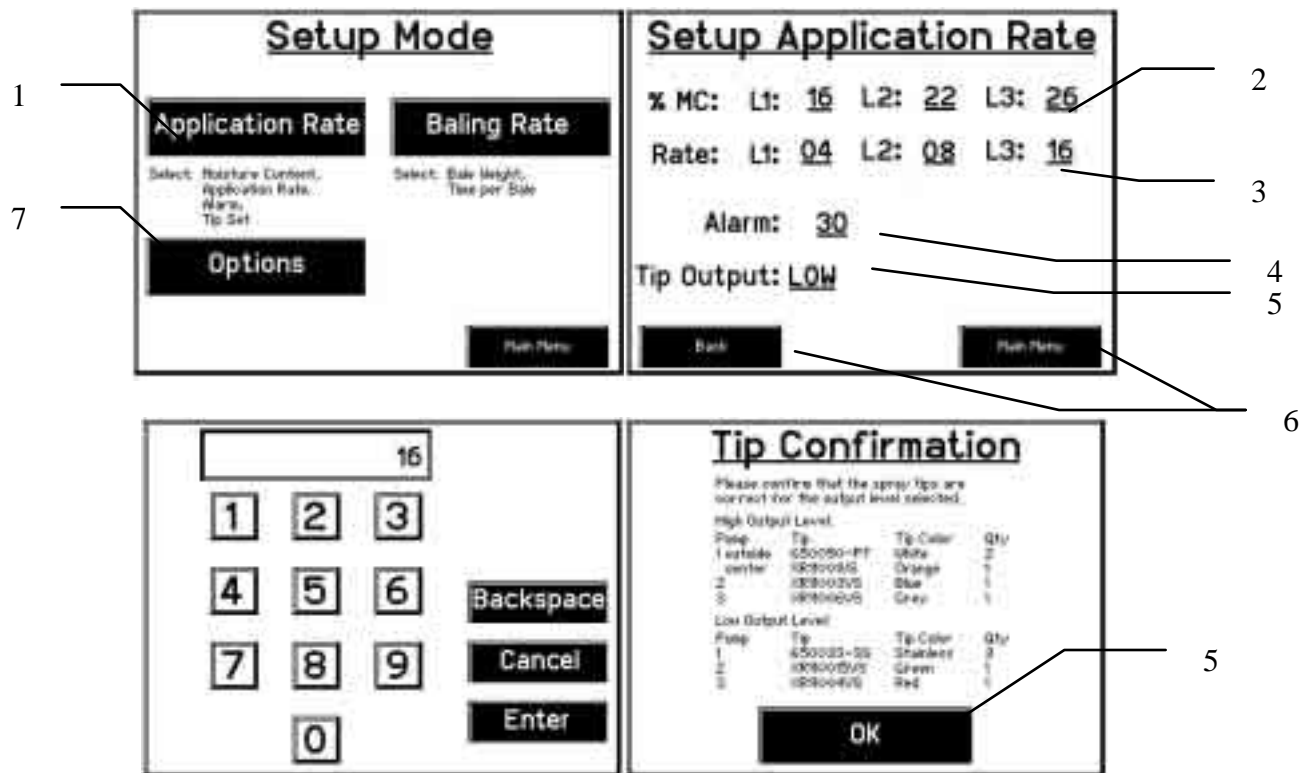

1. On this screen the operator will press the APPLICATION RATE key. Once pressed the SETUP APPLICATION RATE screen will be shown. (Top right picture)
2. Press any of the underlined numbers to the right of %MC to adjust their figures. The key pad shown on the bottom left will display. Remember level 1 must be lower than level 2 and level 2 must be lower than level 3. Harvest Tec products recommend set points of 16,22, and 26 % MC levels. These are preset from the factory. Press ENTER to return to previous screen.
3. To change rate of chemical application, press any of the underlined numbers to the right of RATE:. The key pad shown on the bottom left will display. Remember level 1 must be lower than level 2 and level 2 must be lower than level 3. Harvest Tec products recommend rates of 4,8, and 16 lbs/ton (2,4, and 8 litres/tonne). These rates are preset from the factory. Press ENTER to return to previous screen. **IT IS THE OPERATORS RESPONSIBILITY TO FOLLOW THE RECOMMENDATIONS OF THE PRESERVATIVE ONLY THE OPERATOR CAN APPLY THE PROPER RATE**
4. To set the alarm press on the underlined area and set the level at which you want the alarm to activate. To turn the alarm off, set level above 35.
5. To change the tip output setting to either low or high, press the underlined word to the right of Tip Output:. In the TIP CONFIRMATION screen the operator can verify and change tip selection. After the tips have been verified or changed, press the OK key to return to the previous screen.
6. Next press the BACK key found on the bottom left hand figure of the screen to return to SETUP MODE screen or press MAIN MENU key on the bottom right hand figure of the screen to return to the opening screen.
7. Press OPTIONS to adjust the unit between metric and standard units.

BALING RATE

After pushing the SETUP MODE key in the Main Menu screen, the top screen should appear:

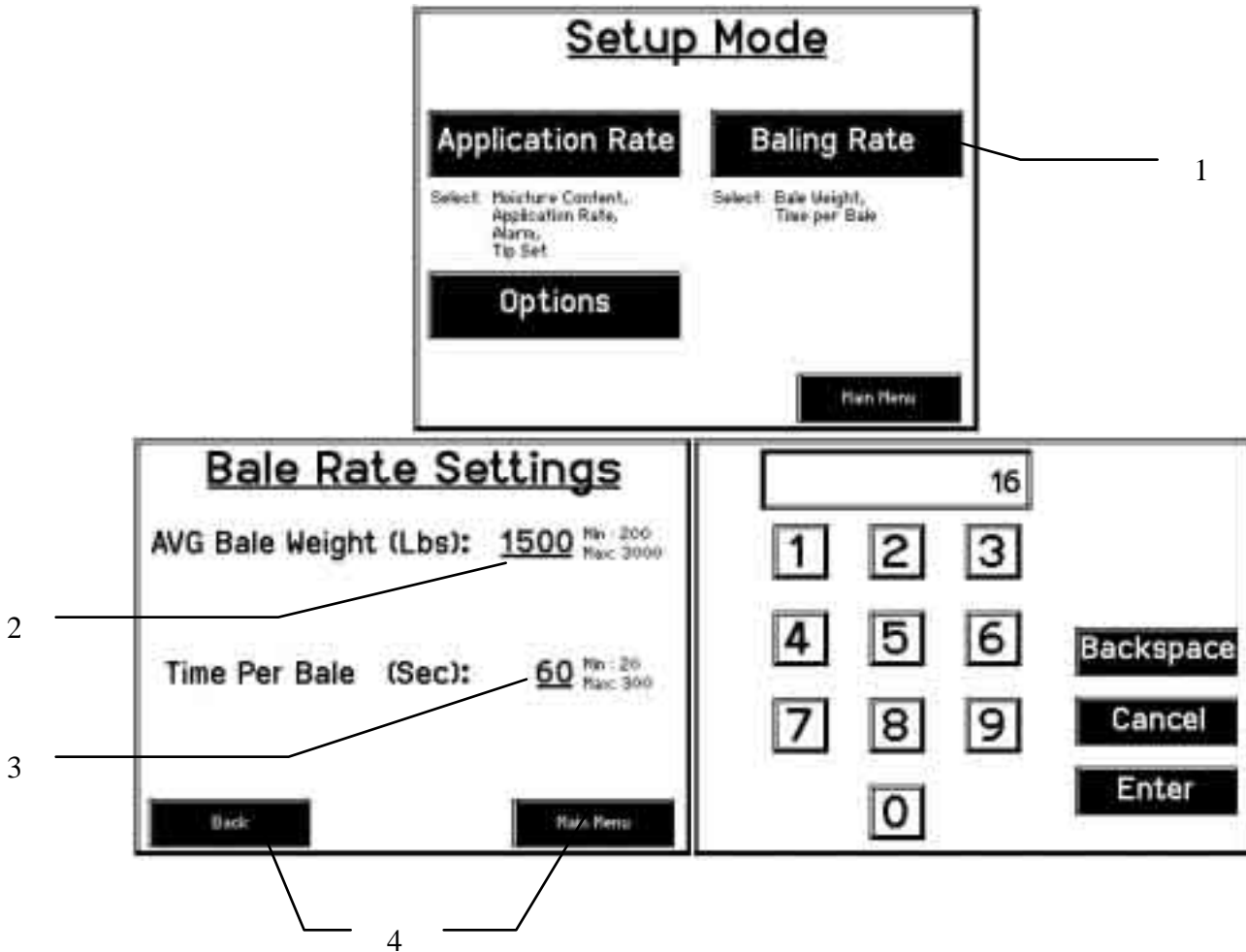

1. On this screen the operator will press the BALING RATE key. This screen is shown on the bottom left side picture shown above.
2. Press the underlined number to the right of AVG Bale Weight (Lbs or Kgs): to adjust the weight of your bales. The keypad shown on the right side will display. Press any number combination in this screen within the min/max limits. Press the ENTER key to save this information. The information will remain until it is changed again.
3. Press the underlined number to the right of Time Per Bale (Sec): to adjust the time it takes to make a bale. The keypad shown on the right side will display. Press any number combination in this screen within the min/max limits. Press the ENTER key to save this information. The information will remain until it is changed again.
4. Next press the BACK key found on the bottom left hand figure of the screen to return to SETUP MODE screen or press the MAIN MENU key on the bottom right hand of the screen to return to the opening screen.

OPERATING INSTRUCTIONS

Auto mode will automatically apply product based on hay moisture content sensed by the moisture discs and the operator's presets. (See SETTING UP SYSTEM FOR INITIAL USE to change any of these settings). **Manual mode will apply preservative to the hay at a fixed rate regardless of the moisture content.**

AUTOMATIC MODE

After pushing the AUTOMATIC MODE key in the Main Menu screen, the following screen should appear:

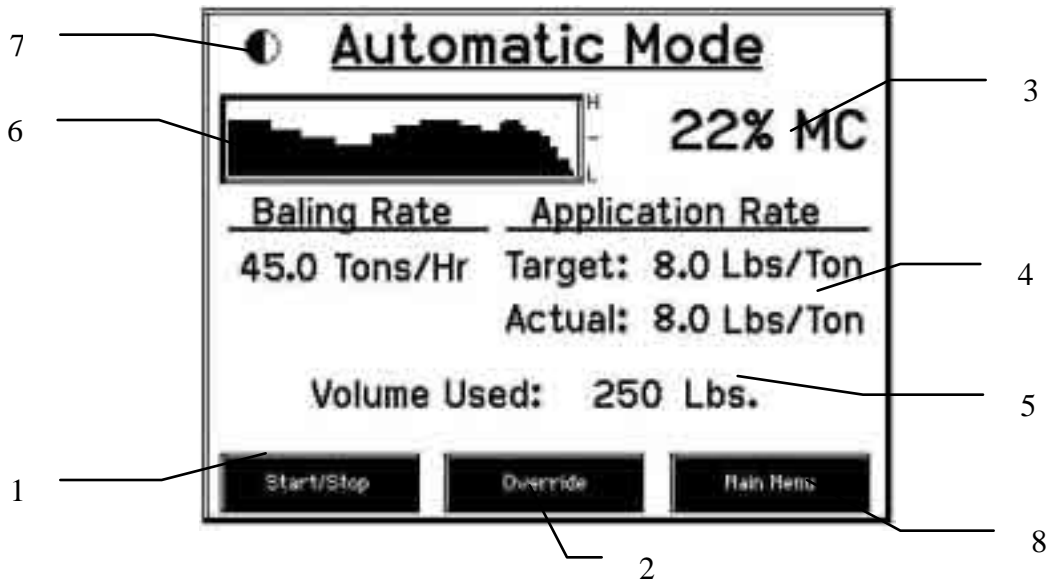

1. Push the START/STOP key to pause the unit while in operation.
2. Push the OVERRIDE key to turn on all three pumps at the same time for full output of the system. Use this mode when going through a short area of wet crop.
3. The moisture content is shown in the upper right hand corner.
4. Baling Rate and Application Rate are shown in the middle. The operator sets the target application rate in the setup mode; the actual rate should be within +/- one pound (litre) when running. The baling rate is also set in Setup Mode.
5. Volume used shown at the bottom of the screen will show accumulated pounds (litres) of preservative used on the go. This number will reset at power down, but remains in the job record screen. **NOTE: Initial start-up requires pressing the New Job key in the Job Records screen in order for Volume Used accumulation to be recorded. This only needs to be done once on initial start-up of system and not every time the system is started for operation.** (See JOB RECORDS screen)
6. The graph shows the moisture trend from the past 90 seconds in 3 second intervals.
7. This button is your contrast control. Press this button to darken the screen. When the screen reaches its darkest point, when the button is next depressed it will return to lightest setting.
8. Press the MAIN MENU key to return to the opening screen.

MANUAL MODE

After pushing the MANUAL MODE key in the Main Menu screen, the following screen should appear:

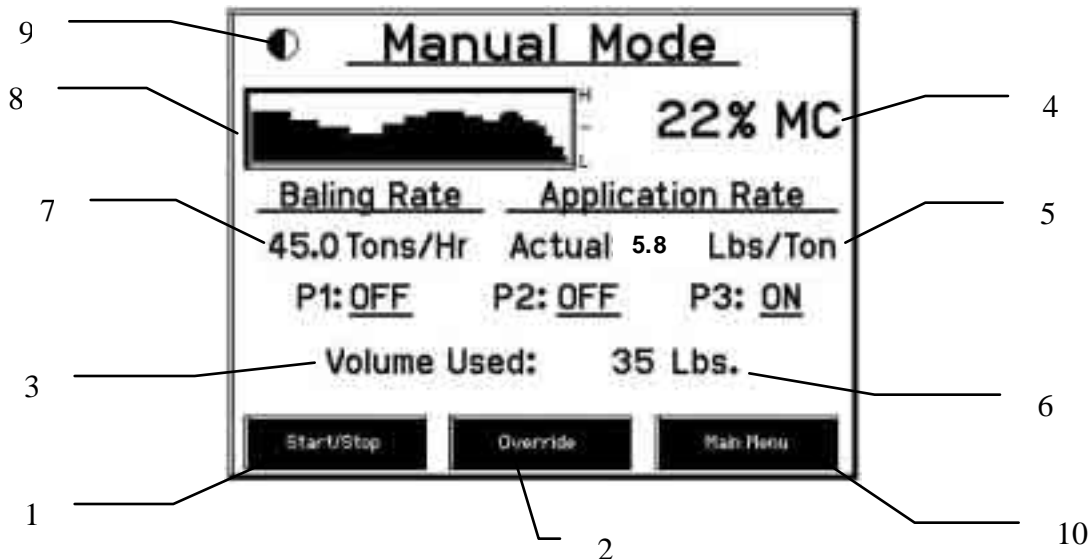

1. Push the START/STOP key to pause the system while in operation.
2. Push the OVERRIDE key to turn on all three pumps at the same time for full output of the system. Use this mode when going through a short area of wet crop.
3. In Manual Mode you can turn the pumps on or off by pressing the underlined area next to the pump numbers. In Manual Mode (regardless of moisture, baling rate or bale weight) the outputs of the pumps are fixed rates as follows:

Low output tips:

Pump 1 = 45 LBS/HR (19 L/HR)
Pump 2 = 90 LBS/HR (38 L/HR)
Pump 3 = 135 LBS/HR (57 L/HR)

High output tips:

Pump 1 = 75 LBS/HR (32 L/HR)
Pump 2 = 140 LBS/HR (59 L/HR)
Pump 3 = 265 LBS/HR (111 L/HR)

4. The moisture content is shown in the upper right hand corner.
5. Baling rate and Application rate are shown in the middle. The output of a pump can be checked by dividing the preset output (shown in step 3) by the displayed baling rate. For example, if you have the high output tips in and are running pump three, by itself, your output is 265 lbs/hr (119 L/hr). Given the baling rate shown on the above screen of 45.0 tons/hr (40.8 MT/hr), the application rate should be about 5.8 lbs/ton (2.6 L/MT) (265 lbs/hr divided by 45.0 tons/hr).
6. Volume used shown at the bottom of the screen will show accumulated pounds (litres) of preservative used on the go. This number will reset at power down, but remains in the job record screen. **NOTE: Initial start-up requires pressing the New Job key in the Job Records screen in order for Volume Used accumulation to be recorded. This only needs to be done once on initial start-up of system and not every time the system is started for operation.** (See JOB RECORDS screen)
7. The baling rate is set in the SETUP MODE menu.
8. This graph shows the moisture trend from the last 90 seconds of baling (one reading every 3 seconds).
9. This button is your contrast control. Press this button to darken the screen. When the screen reaches its darkest point, when the button is next depressed it will return to lightest setting.
10. Press the MAIN MENU key to return to the opening screen.

JOB RECORDS

After pushing the JOB RECORDS key in the Main Menu screen, the following screen should appear:

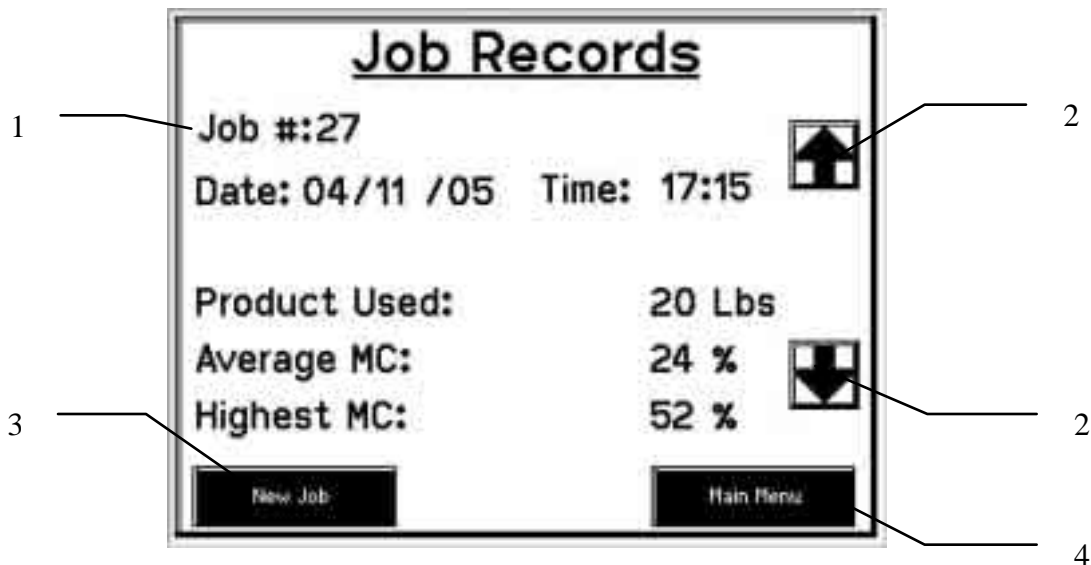

1. The job number will be displayed in the top left corner and will move to the next job when the NEW JOB key is pressed. The current job being viewed will always read "Job #: 0". Product used and average moisture content will be reset when the NEW JOB key is pressed. The job records screen will store up to 63 jobs and will allow you to access previous jobs by using the up and down arrows found on the right side of the screen.
2. Scrolling through previous jobs is done by pressing the UP or Down keys.
3. **Every time the NEW JOB key is pressed the accumulated pounds (litres) on auto and manual modes will be reset to zero.** After 63 jobs have been stored, the next time the NEW JOB key is pressed the system will start over with job one and the old job will be replaced.
4. To return the opening screen, press the MAIN MENU key.
NOTE: Initial start-up requires pressing the New Job key in the Job Records screen in order for Volume Used accumulation to be recorded. This only needs to be done once on initial start-up of system and not every time the system is started for operation.

DIAGNOSTICS

After pushing the DIAGNOSTICS key in the Main Menu screen, the following screen should appear:

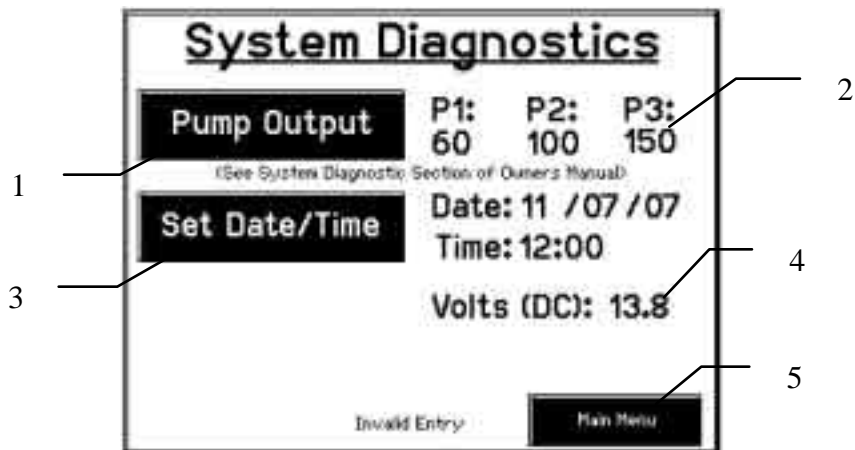

The diagnostic mode will automatically check the pump output and performance of the three pumps. It is recommended to use this mode daily to ensure proper system performance.

Acceptable ranges for output:

Low output tips:

Pump 1 = 38 - 53 LBS/HR (16 – 22 L/HR)
Pump 2 = 76 - 105 LBS/HR (32 – 44 L/HR)
Pump 3 = 115 - 160 LBS/HR (48 – 67 L/HR)

High output tips:

Pump 1 = 64 - 88 LBS/HR (27 – 37 L/HR)
Pump 2 = 119 - 165 LBS/HR (50 – 69 L/HR)
Pump 3 = 225 - 312 LBS/HR (95 – 131 L/HR)

1. Once the screen is displayed, press the PUMP OUTPUTS key.
The machine will cycle all three of the pumps for 15 seconds. After the cycles are complete, the system will display a number next to each pump number.
2. **If the system displays within the listed range.**
 - A. The system is operating correctly.

If the system displays higher than the listed range, some common problems could be:

 - A. Leak in line. Inspect lines thoroughly.
 - B. Tip missing. Check for lost or broken tip on spray shield.
 - C. Tip worn. Replace tip.
 - D. High tractor voltage.

If the system displays lower than the listed range, some common problems could be:

 - A. Make sure there is preservative in the tank and ball valve is in the open position.
 - B. Air in lines. Pump will not prime. Check for leak in lines, or defective check valve.
 - C. Pump is working, but not producing desired output. Pump needs to be rebuilt.
 - D. Main filter plugged. Check filter by tank and clean if necessary.
 - E. Tip or tip screen plugged. Check both tip and tip screen and clean if necessary.
 - F. Kink in hose. Straighten or replace hose.
 - G. Voltage from tractor is low. Check power cord with multimeter for 12 volts at baler mounted processor. Clean connections on battery. Dielectric grease connections at baler mounted processor and at hitch connection.
 - H. Pump is defective. Rebuild pump if motor runs smoothly. Replace pump if motor is bad.
 - I. Defective flow meter. Only if all pumps run, product is applied, and all numbers read 0.
3. To set date and time, press the SET DATE/TIME key. In the next screen enter the date (month, day, year format) followed by the time. When done press the ENTER key. NOTE: The clock uses military (or 24 hour) time.
4. The voltage should be between 12.0 to 14.5 volts for the system to work properly. If voltage is not in this range check all power cord connections and the tractors charging system.
5. When done in this mode, press the MAIN MENU key.

COMMON QUESTIONS ABOUT THE 463

1. How do I turn the system on/off?

To turn the system ON simply press anywhere on the right side of the screen followed by pressing the “Press to Start” key. To turn the system OFF, return to the Main Menu screen and press the POWER OFF key.

2. How to get in the LBS/TON, MC%, and TONS/HR menus?

In the Main Menu press the SETUP MODE key. From this screen you can change your application rates and how much product is applied. See Setting Up System For Initial Use for a detailed explanation of this process.

3. The unit is stuck in the MC% screen.

In the MC% screen, level 1 must be less than level 2, and level 2 must be less than level 3. For example, if level 1 is set at 16, level 2 must be set at 17 or higher, and level 3 must be set higher than level 2.

4. How does OVERRIDE work?

Override turns on all three pumps at full output. The pumps will remain at full output until the operator turns these pumps off by pressing the OVERRIDE key again.

5. The flow meter reading is more or less than the programmed level set in the box.

Some variation in flow meter readings compared to the programmed set point is normal due to factory tolerances on the pump motors as well as varying tractor voltages inputted to the control box. The flow meter reading is an accurate measure of how much product is actually being applied. The set points then will need to be adjusted if you want to attain a different flow meter reading.

6. Why don't all the pumps turn on even at higher application rates?

The selections of what pumps turn on when, are automatically controlled by the control box's flow rate look up chart. Thus, not all the pumps turn on at once and the combination of what pumps turn on when, is automatically controlled by the software. If you want to make sure all three pumps are working, go to the Diagnostics screen and run pump outputs.

7. The moisture content displays “LO” or “HI” all the time.

When the moisture content display does not change frequently while baling, there is likely a faulty moisture pad connection. Check the moisture testing wire and connectors to see if there is a continuity or grounding problem.

MAINTENANCE

1. Clean the tip strainers and main strainer every 10 hours of operation or more frequently if required.
2. Depending on the product being used, the system may need to be flushed with water at a regular interval (consult with manufacturer of the chemical.) If Harvest Tec product is being used, flushing is not necessary.
3. Although the pump can run dry, extended operation of a dry pump will increase wear. Watch the preservative level in the tank.
4. Cover the automatic cab terminal on open station tractors if left outside.
5. Pump performance may start to decline after 400 hours (5000 bales on large round balers) of use. Rebuilding the pump is a simple procedure if the motor is not damaged. Order pump rebuilding kit #007-4581 for the automatic unit.
6. If you are using bacterial inoculants, flush your system daily after every use.
7. Clean tank cap every 10 hours of operation.

Maintenance Schedule

	Daily	10 hrs	400 hrs	Weekly	Monthly	Season
Diagnostics	X					X
Filter bowl cleaning		X				X
Tip screen cleaning		X				X
Tank cap cleaning		X				X
Dielectric grease connections					X	X
Rebuild pump			X			
Battery connections				X		X
Check valves			X			
Visually inspect hoses				X		X

WINTER STORAGE

1. Thoroughly flush the system with water.
2. Remove the filter bowl and run dry until the water has cleared out of the intake side.
3. Remove the red plug from the bottom of the pump, drain, and run the pump for 30 seconds or until it is dry.
4. Drain all lines on the outlet side.
5. Never use oils or alcohol based anti-freeze in the system.
6. For spring start-up, if the pump is frozen, turn off the power immediately to avoid burning the motor out. The pump head can be disassembled and freed or rebuilt in most cases.
7. Disconnect power from the system.
8. Remove display from the tractor and store in a warm, dry place.

TROUBLE SHOOTING CHECKS:

<u>PROBLEM</u>	<u>POSSIBLE CAUSE</u>	<u>SOLUTION</u>
Pump will not run.	1. No voltage to Baler Mounted Processor.	1. Check for short, low voltage, and replace fuse if necessary.
	2. Pump locked up.	2. Clean or rebuild pump if motor is OK.
	3. Damaged wire.	3. Repair damaged wire.
Pump runs but will not prime.	1. Air leak in intake.	1. Tighten fittings on intake side.
	2. Clogged intake.	2. Clean.
	3. Restricted outlet.	3. Check and clean tips.
	4. Check valve on outlet stuck closed.	4. Clean or repair check valve.
	5. Dirt inside pump.	5. Replace pump check valve.
Pump does not develop enough output.	1. Air leaks or clogs on inlet side.	1. Tighten or clean filter bowl assembly.
	2. Pump worn or dirty.	2. Rebuild pump.
Moisture reading errors (high or low)	1. Wire disconnected or bad connection between moisture discs and baler mounted processor.	1. Reconnect wire.
	2. Low power supply to baler mounted processor.	2. Check voltage at box. (Min of 12 volts required.) See Diagnostics section of manual.
	3. Wet hay over 32% moisture	
	4. Ground contact with one or both moisture discs and baler mounted processor.	4. Reconnect.
	5. Short in wire between moisture discs and baler mounted processor.	5. Replace wire.
	6. Check hay with hand tester to verify.	6. Contact Harvest Tec if conditions persist.
Moisture readings erratic.	1. Test bales with hand tester to verify that cab monitor has more variation than hand tester.	
	2. Check all wiring connections for corrosion or poor contact.	2. Apply dielectric grease to all connections.
	3. Check power supply at tractor. Voltage should be constant between 12 and 14 volts.	3. Install voltage surge protection on tractors alternator.
Flow meter readings do not match up with product usage.		
Product is less than actual product used.	1. Voltage supplied to meter is less than 6 volts.	1. Check for a min of 6 volts supplied at baler mounted processor.
	2. Wiring short in signal to baler mounted processor.	2. Inspect wire and replace if necessary.
	3. Clog in meter.	3. Back flush with water. DO NOT USE AIR.

Product shown is more than actual product used.	1. High voltage supplied to the meter.	1. Check voltage at baler mounted processor. Max of 18 volts.
	2. Light interference with meter.	2. Reflection into meter can cause a high reading. Move meter or protect from sunlight.
	3. Air leak in intake.	3. Look for air bubbles in line. Replace line or other defective area that is allowing air into the system.
System leaks product out of tips after shutdown.	1. Dirty or defective check valves.	1. Clean or Replace.
Terminal reads under or over power.	1. Verify with multi-meter actual voltage. Voltage range should be between 12-14 volts.	1. Clean connections and make sure applicator is hooked to battery. See Diagnostics section of manual.
System always displays "End of Row Pause".	1. Flow meter connector plug is plugged into Hay Indicator port on Baler Mounted Processor.	1. Switch ports.
Display will not power up.	1. Display connector plug and bale rate sensors plug are switched on the Baler Mounted Processor.	1. Switch plugs.
	2. Display and BMP not communicating.	2. Disconnect 12 volt power cable at hitch. DO NOT DISCONNECT DISPLAY CABLE. Wait 5 minutes and reconnect.
Display says waiting for BMP	1. Display and BMP not communicating.	1. Disconnect 12 volt power cable at hitch. DO NOT DISCONNECT DISPLAY CABLE. Wait 5 minutes and reconnect.

BACKUP FUSE

The Model 463 is equipped with a backup system if your display is not functioning. This function is intended for use only as a temporary means for application and not as a way to apply preservative over multiple fields or for a lengthy amount of time. The baler mounted processor has a location for a backup fuse on the same side as the pump and flow meter harness that bypasses all other system inputs and applies preservative using one pump (Pump Three) at a constant lbs/hour shown below. These values are based upon an input voltage of 13.5 DC. Insert at least a 10 amp up to 20 amp fuse (3 AG style) into the backup fuse port to activate the bypass. The system will not turn off or pause until the fuse is removed. The main fuse must also be functional for the backup fuse to work.

	Tip Set	Output (lbs/hour)
463	High	230 (104 L/HR)
	Low	180 (81 L/HR)

WIRING DIAGRAMS

A. Main power connector mounted on battery

Pin 1	Red	+ 12 V input from tractor supply
Pin 2	Black	Ground from tractor supply
Pin 3	Not used	



B. Main power connector mounted on BMP

Pin 1	Red	+ 12 V input from tractor supply
Pin 2	Black	Ground from tractor supply
Pin 3	Not used	

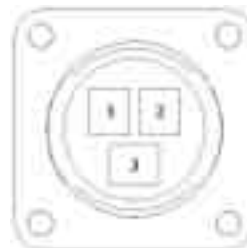

C. Pump connection colors

Pin 1	Black with orange markings	Pump 1 ground
Pin 2	Black with green markings	Pump 2 ground
Pin 3	Black with yellow markings	Pump 3 ground
Pin 4	Not used	
Pin 5	Orange with black markings	Pump 1 positive
Pin 6	Green with black markings	Pump 2 positive
Pin 7	Yellow with black markings	Pump 3 positive

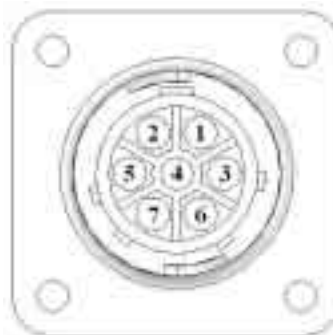

D. Flow meter connection on BMP

Pin 1	White	5 - 12 V (+) supply
Pin 2	Green	Ground
Pin 3	Brown	Signal
Pin 4	Black	Shield



E. Connector for Hay Indicator option on BMP

Note: Hay indicators are an option that will turn the system on and off automatically as hay enters the pickup of the baler.

Pin 1	Red	+12V
Pin 2	Black	Ground
Pin 3	White	Signal wire
Pin 4	Not used	



G. Star wheel connector mounted on BMP

Pin 1	Brown	Star wheel input 1
Pin 2	Blue	Star wheel input 2
Pin 3	Brown	Diagnostic 1
Pin 4	Blue	Diagnostic 2
Pin 5	Silver	Shield
Pin 6	Silver	Shield
Pin 7	Not used	
Pin 8	Not used	
Pin 9	Not used	



H. Communication harness display to hitch

Pin 1	Red	Power to display
Pin 2	Black	Ground to display
Pin 3	Blue	Comm channel OH
Pin 4	Orange	Comm channel OL

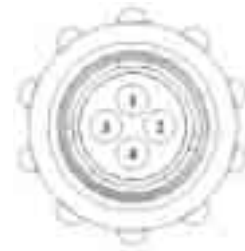

I. Communication harness hitch to baler mounted processor

Pin 1	Red	Power to display
Pin 2	Black	Ground to display
Pin 3	Blue	Comm channel OH
Pin 4	Orange	Comm channel OL



HARVEST TEC MODEL 449 BASE KIT

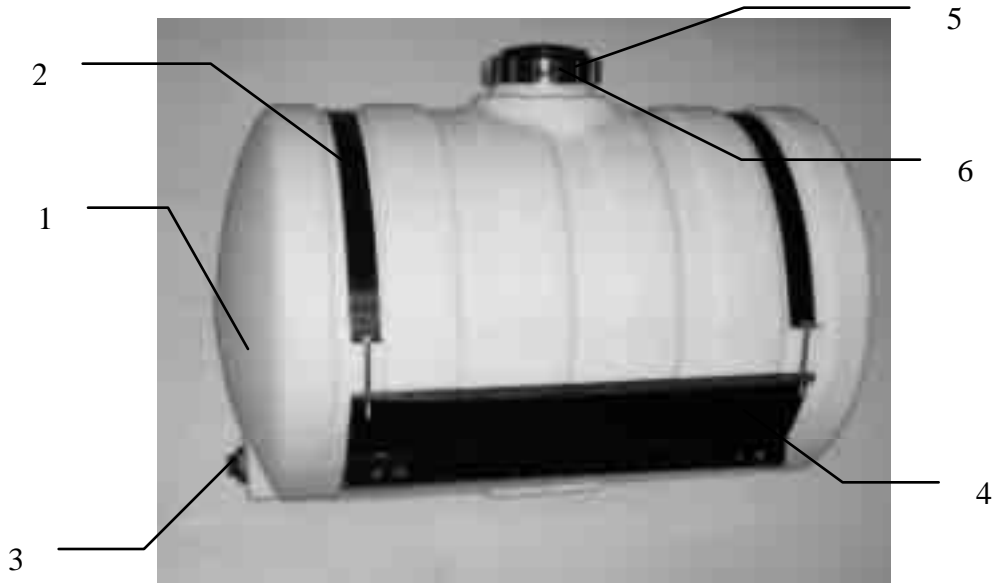

<u>Ref#</u>	<u>Description</u>	<u>Part #</u>	<u>Qty</u>
1	Tank	005-9023	1
2	Straps	001-4402	2
3	Tank Fitting	005-9100	2
4	Saddle	001-4703	1
5	Tank Cap	005-9022C	1
6	Tank Gasket	005-9022CG	1

PARTS BREAKDOWN FOR DRAIN FILL KIT



<u>Ref #</u>	<u>Description</u>	<u>Part #</u>	<u>Qty</u>	<u>Ref #</u>	<u>Description</u>	<u>Part #</u>	<u>Qty</u>
1	Straight Fitting	003-A3434	1	5	Male Coupler	002-2205G	1
2	Elbow	003-EL3434	1	6	Valve Holder	001-6702H	1
3	Hose Clamps	003-9004	2	7	Ball Valve	002-2200	1
4	Female Coupler	002-2204A	1	8	Jiffy Clip	008-9010	3

PARTS BREAKDOWN FOR PUMP PLATE

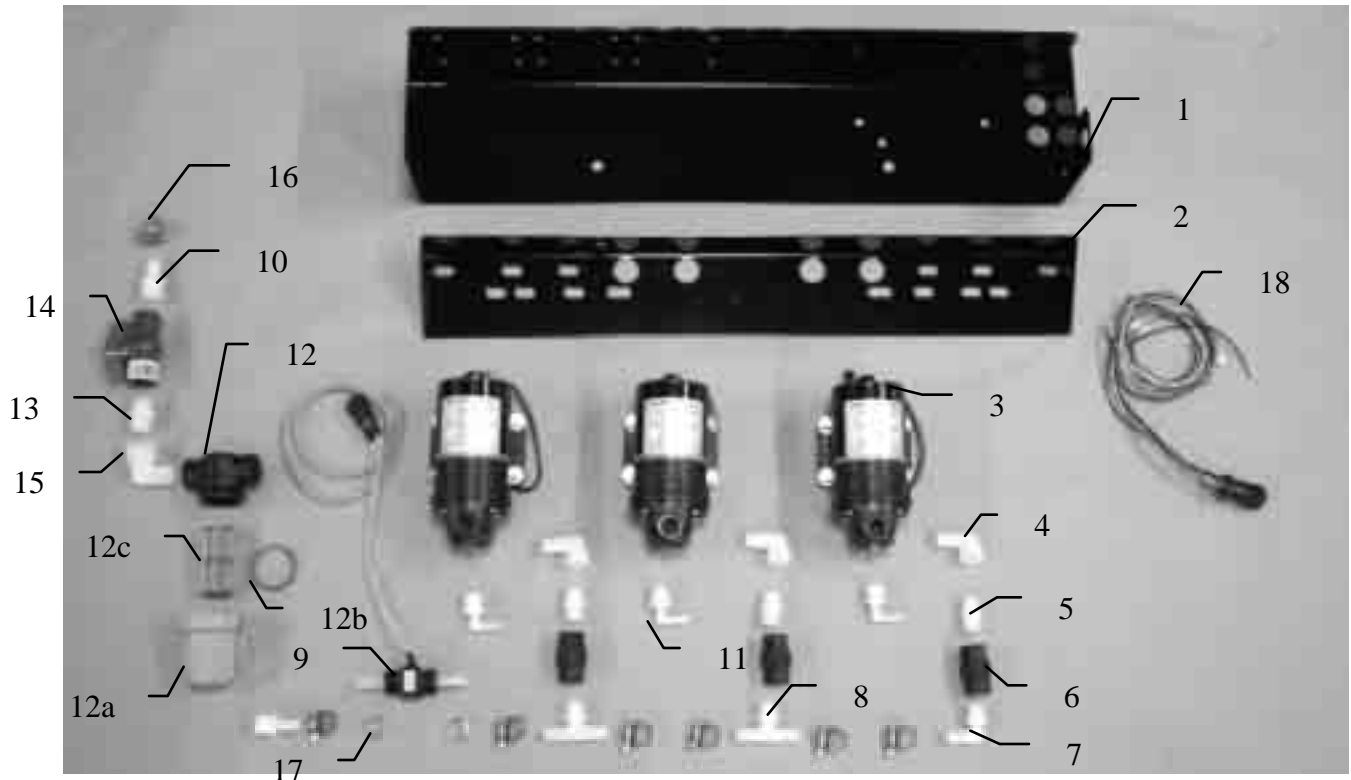

<u>Ref#</u>	<u>Description</u>	<u>Part#</u>	<u>Qty</u>
1	Pump plate	001-4646D	1
2	Mounting Bracket	001-4646C	1
3	Pump	007-4120H	3
4	Street elbow fitting	003-SE38	3
5	Nipple fitting	003-M3838	3
6	Check valve	002-4566F	3
7	Elbow fitting	003-EL3812	1
8	Tee fitting	003-T3812HB	2
9	Flow meter assembly	006-4725A	1
10	Straight fitting	003-A1212	2
11	Elbow fitting	003-EL3814	3
12	Filter bowl assembly	002-4315	1
12a	Filter bowl only	002-4315F	1
12b	Filter bowl gasket	002-4315D	1
12c	Filter bowl screen	002-4315B	1
13	Nipple fitting	003-M1212	1
14	Ball valve	002-2212	1
15	Street elbow fitting	003-SE12	1
16	Hose clamp	003-9003	7
17	Hose clamp (Flow Meter)	003-9005	2
18	Pump Cable	006-4660Z	1
NP	Pump rebuild kit (1 per pump)	007-4581	1
NP	Not Pictured		

MOISTURE PAD AND HOSES PARTS BREAKDOWN

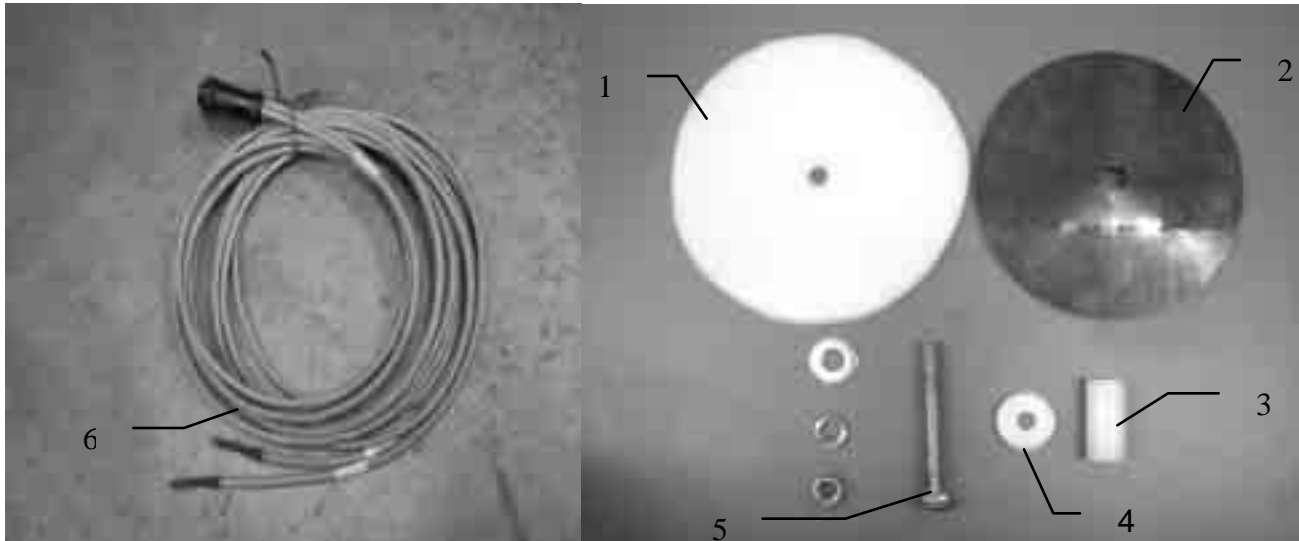

<u>Ref#</u>	<u>Description</u>	<u>Part #</u>	<u>Qty</u>
1	Plastic Pad	006-4641F	2
2	Moisture Disc	006-4641H	2
3	Plastic Bushing	006-4641G	2
4	Plastic Isolator	006-4641I	2
5	1/2X4 1/2" Carriage Bolt		2
6	Moisture Cable	006-4640G	1
1-5	Moisture Pad Assembly	030-4643	2



<u>Ref</u>	<u>Description</u>	<u>Part#</u>	<u>Qty</u>
1	Triple weld hose (from pumps to tips)	002-9016	15ft
		002-9016B	15ft
		002-9016G	15ft
	Hose assembly (3 hose assembly)	030-9016RB	1
2	1/2" Hose (tank to filter)	002-9001	6ft

PARTS BREAKDOWN FOR CONTROL BOX AND WIRING HARNESS

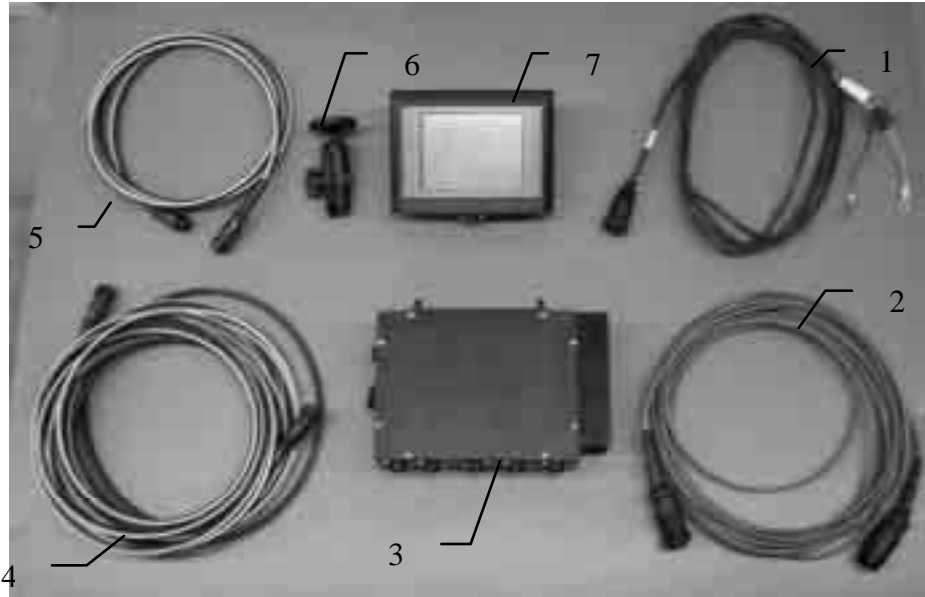

<u>Ref.</u>	<u>Description</u>	<u>Part#</u>
1	Power Lead Tractor	006-4640A
2	Power Lead Baler	006-4660R
3	Baler Mounted Processor	006-4671RB
4	Communication Harness (baler)	006-4660S
5	Communication Harness (tractor)	006-4660N
6	Ram Mount	001-2012H
7	463 Terminal	006-4670

HARVEST TEC MODEL 4503B INSTALLATION KIT FOR JOHN DEERE EUROPEAN ROUND BALERS, AUTOMATIC CONTROL

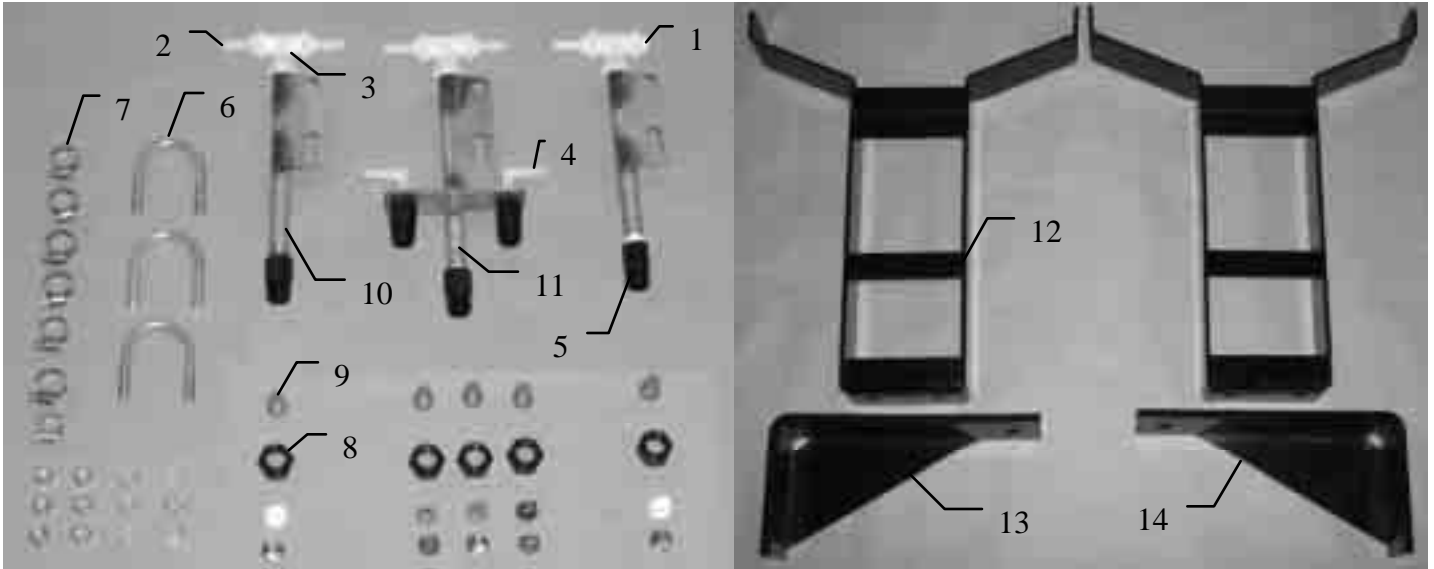

<u>Ref</u>	<u>Description</u>	<u>Part#</u>	<u>Qty</u>	<u>Ref</u>	<u>Description</u>	<u>Part#</u>	<u>Qty</u>
1	Plug	003-F14	1		Tip	004-650033-SS	3
2	Straight fitting	003-A1414	5		Tip	004-XR110015VS	1
3	Tee	003-TT14	3		Tip	004-XR11004VS	1
4	Elbow	003-EL1414	2		Tip	004-650050-PT	2
5	Nozzle body	004-4721	5		Tip	004-XR11001VS	1
6	U bolt	001-4714UBS	3		Tip	004-XR11003VS	1
7	Hose clamp	003-9002	7		Tip	004-XR11006VS	1
8	Nozzle cap	004-4723	5				
9	Tip strainer with check	004-4213-200	5				
10	Nozzle tube	001-4714P	2				
11	Nozzle tube auto	001-4714AP	1				
12	Saddle legs	001-4703B	2				
13	Left mtg bracket	001-4703EL	1				
14	Right mtg bracket	001-4703ER	1				

HARVEST TEC MODEL 4512B INSTALLATION KIT FOR VICON 1601/1901 WITH AUTOMATIC CONTROL

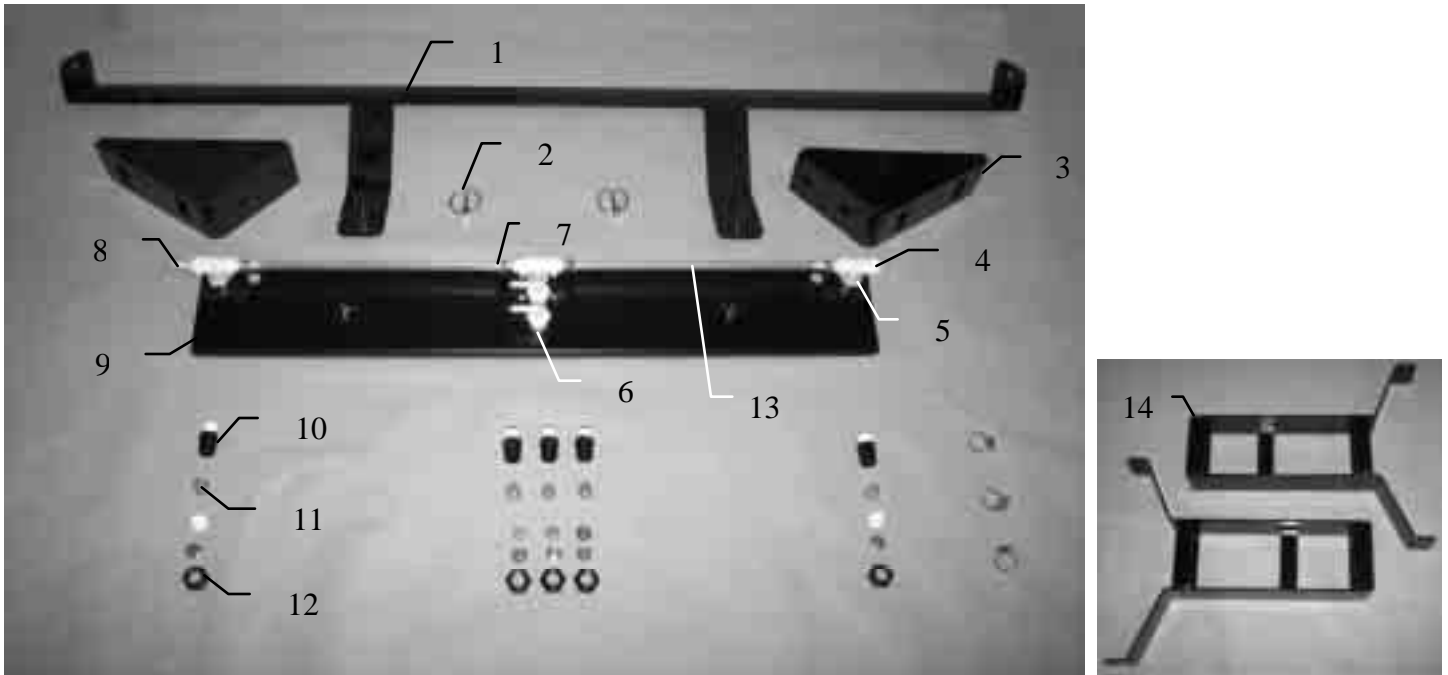

<u>Ref #</u>	<u>Description</u>	<u>Part #</u>	<u>Qty</u>	<u>Ref #</u>	<u>Description</u>	<u>Part #</u>	<u>Qty</u>
1	Shield holder	001-4704E	1	NP	Tip	004-650033-SS	3
2	Lynch pin	008-4576	2	NP	Tip	004-XR110015VS	1
3	Mounting bracket	001-4704F	2	NP	Tip	004-XR11004VS	1
4	Plug	003-F14	1	NP	Tip	004-650050-PT	2
5	Tee	003-TT14	3	NP	Tip	004-XR11001VS	1
6	Elbow	003-EL1414F	2	NP	Tip	004-XR11003VS	1
7	Hose clamp	003-9002	7	NP	Tip	004-XR11006VS	1
8	Straight fitting	003-A1414	5				
9	Spray shield	001-4703GR	1	NP	Not Pictured		
10	Nozzle body	004-4722	5				
11	Tip strainer	004-4213-200	5				
12	Nozzle cap	004-4723	5				
13	Hose	002-9016	2				
14	Legs	001-4703B	2				

NOTES:

WARRANTY AND LIABILITY AGREEMENT

Harvest Tec, Inc. will repair or replace components that are found to be defective within 12 months from the date of manufacture. Under no circumstances does this warranty cover any components which in the opinion of Harvest Tec, Inc. have been subjected to negligent use, misuse, alteration, accident, or if repairs have been made with parts other than those manufactured and obtainable from Harvest Tec, Inc.

Our obligation under this warranty is limited to repairing or replacing free of charge to the original purchaser any part that in our judgment shows evidence of defective or improper workmanship, provided the part is returned to Harvest Tec, Inc. within 30 days of the failure. Parts must be returned through the selling dealer and distributor, transportation charges prepaid.

This warranty shall not be interpreted to render Harvest Tec, Inc. liable for injury or damages of any kind, direct, consequential, or contingent, to persons or property. Furthermore, this warranty does not extend to loss of crop, losses caused by delays or any expense prospective profits or for any other reason. Harvest Tec, Inc. shall not be liable for any recovery greater in amount than the cost or repair of defects in workmanship.

There are no warranties, either expressed or implied, of merchantability or fitness for particular purpose intended or fitness for any other reason.

This warranty cannot guarantee that existing conditions beyond the control of Harvest Tec, Inc. will not affect our ability to obtain materials or manufacture necessary replacement parts.

Harvest Tec, Inc. reserves the right to make design changes, improve design, or change specifications, at any time without any contingent obligation to purchasers of machines and parts previously sold.

Revised 01/03/06

HARVEST TEC, INC.
P.O. BOX 63
2821 HARVEY STREET
HUDSON, WI 54016
PHONE: 715-386-9100
1-800-635-7468
FAX: 715-381-1792
Email: info@harvesttec.com